

1 2 3 4 5 6 7 8

| 更改 REV | 設變內容 MODIFICATION | 日期 DATE | 修改 DRAW |
|-----------|----------------------|------------|------------|
| | | | |
| | | | |
| | | | |

F
E
D
C
B
A

F
E
D
C
B
A

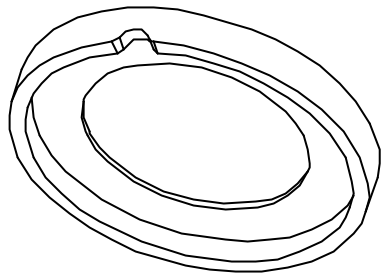
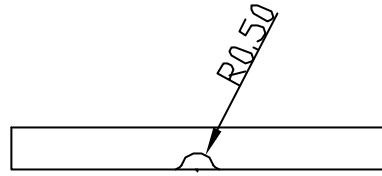

SCALE 3.000

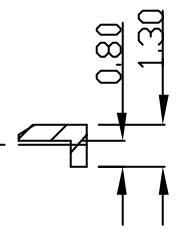
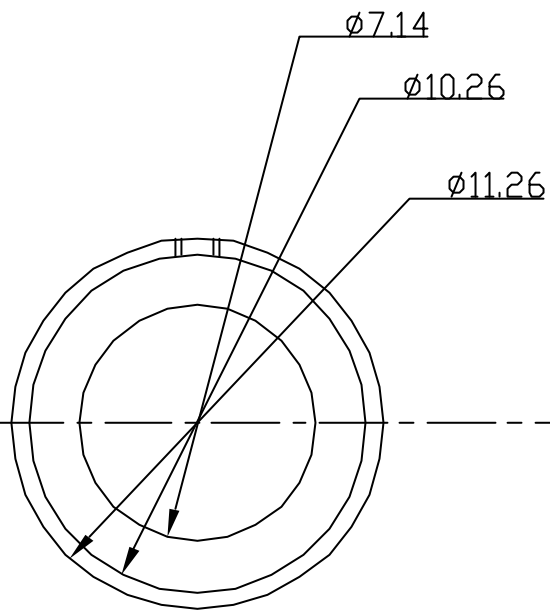

NOTES:

- MATERIAL: SUS304 0.2t
TEXTURE:
BRIGHTNESS: 4~6°
- FLASH TO BE CLEAR FOR P.L. SURFACE
- UNSPECIFIED DIMENSION TOLERANCE SEE TOLERANCE TABLE
- UNSPECIFIED RADIUS TO BE R=0.3mm
- UNSPECIFIED DRAFT ANGLE : 0°30'
- CONCENTRIC CENTER TOLERANCE ± 0.1 mm
- ALL EXTERNAL SURFACE TO BE FREE OF VOIDS.SINK MARKS.KNIT LINS.FLASH. SCRATCHES AND NICKS
- Ⓢ--PROCESS CONTROL
□--CRITICAL CONTROL
- MAX DEFORMATION: Ⓢ0.1MM

SCALE 3.000

1 2 3 4 5 6 7 8

| DIMENSION IN mm [Inch] | | C | |
|--------------------------------------|-------------|---------------------|---|
| TOLERANCE UNLESS OTHERWISE SPECIFIED | | | |
| 0-5±0.05 | 6-20±0.075 | 名稱 TITLE | CUSTOMER DRAWING |
| 21-50±0.10 | 51-110±0.15 | 案號 FILE No. AR27 | 圖號 DWG No. AR27-CMOS-RING |
| >110±0.20 | XX±0.25 | 圖紙 SIZE A4 | 角法 PROJ 日期 DATE 05/06/04 比例 SCALE 3:1 更改 REV A |
| 審核 APPROVE | 核對 CHECK | 製圖 DRAW | |

A